

# MTD1361

## Unipolar motor driver IC (DMOS output)

### Features

- Unipolar drive system
- DMOS output (low loss and Low generation of heat)
- TTL and CMOS compatible gate
- 4-phase input (simultaneous ON prevention function)
- Constant current control
- Integrated flywheel diodes and no external Zener diode needed
- Low thermal resistance ZIP package (ZIP27)



### Absolute maximum ratings / Ta=25°C

Parameter	Symbol	Rating	Unit
Logic input voltage	$V_{IN}$	-0.3 to 6	V
DMOS output breakdown voltage	$V_{DSS}$	68	V
Flywheel diode voltage	$V_R$	68	V
Output current	$I_D$	1.5	A
Flywheel diode current	$I_F$	1.5	A
Power dissipation*	$P_T$	3	W
Storage temperature range	Tstg	-40 to 150	°C
Junction temperature range	Tj	150	°C

### Pin assignment

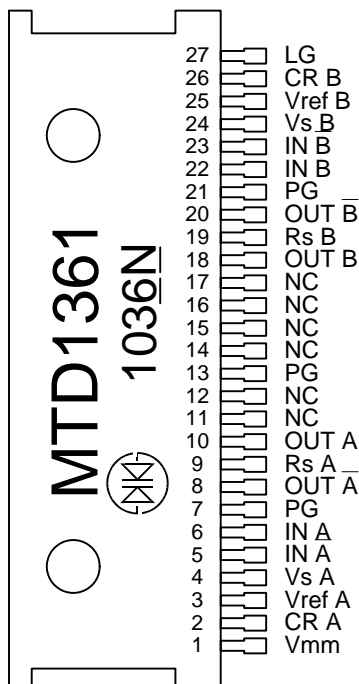

### Truth table

IN A or B	IN $\bar{A}$ or $\bar{B}$	OUT A or B	OUT $\bar{A}$ or $\bar{B}$
L	L	OFF	OFF
L	H	ON	OFF
H	L	OFF	ON
H	H	OFF	OFF

### Electrical characteristics / Ta=25°C

Parameter	Symbol	Condition	MIN	TYP	MAX	Unit
Load supply	Vmm		15.0		30.0	V
Load supply current	I <sub>mm</sub>	V <sub>mm</sub> =24V		18.0		mA
"L" input voltage	V <sub>in</sub> (L)	V <sub>mm</sub> =24V			0.8	V
"H" input voltage	V <sub>in</sub> (H)	V <sub>mm</sub> =24V	2.0			V
"L" input current	I <sub>in</sub> (L)	V <sub>mm</sub> =24V, V <sub>in</sub> =0V			-50.0	μA
"H" input current	I <sub>in</sub> (H)	V <sub>mm</sub> =24V, V <sub>in</sub> =5V			10.0	μA
V <sub>s</sub> input current	I <sub>s</sub> (L)	V <sub>mm</sub> =24V, V <sub>s</sub> =0V			-50.0	μA
V <sub>ref</sub> input current	I <sub>ref</sub> (L)	V <sub>mm</sub> =24V, V <sub>ref</sub> =0V			-50.0	μA
V <sub>ref</sub> input voltage	V <sub>ref</sub>	V <sub>mm</sub> =24V			1.5	V
Output saturation voltage	V <sub>dson</sub>	I <sub>d</sub> =1.2A		0.96		V
Flywheel diode forward drop	V <sub>f</sub>	I <sub>f</sub> =1.2A		1.5		V
One shot OFF time	T <sub>off</sub>	C <sub>t</sub> =3300pF, R <sub>t</sub> =8.2kΩ		18.7		μs

### Thermal resistance

Symbol	Rating	Unit
θ <sub>ja</sub>	25	°C/W

### Internal equation circuits / Typical application

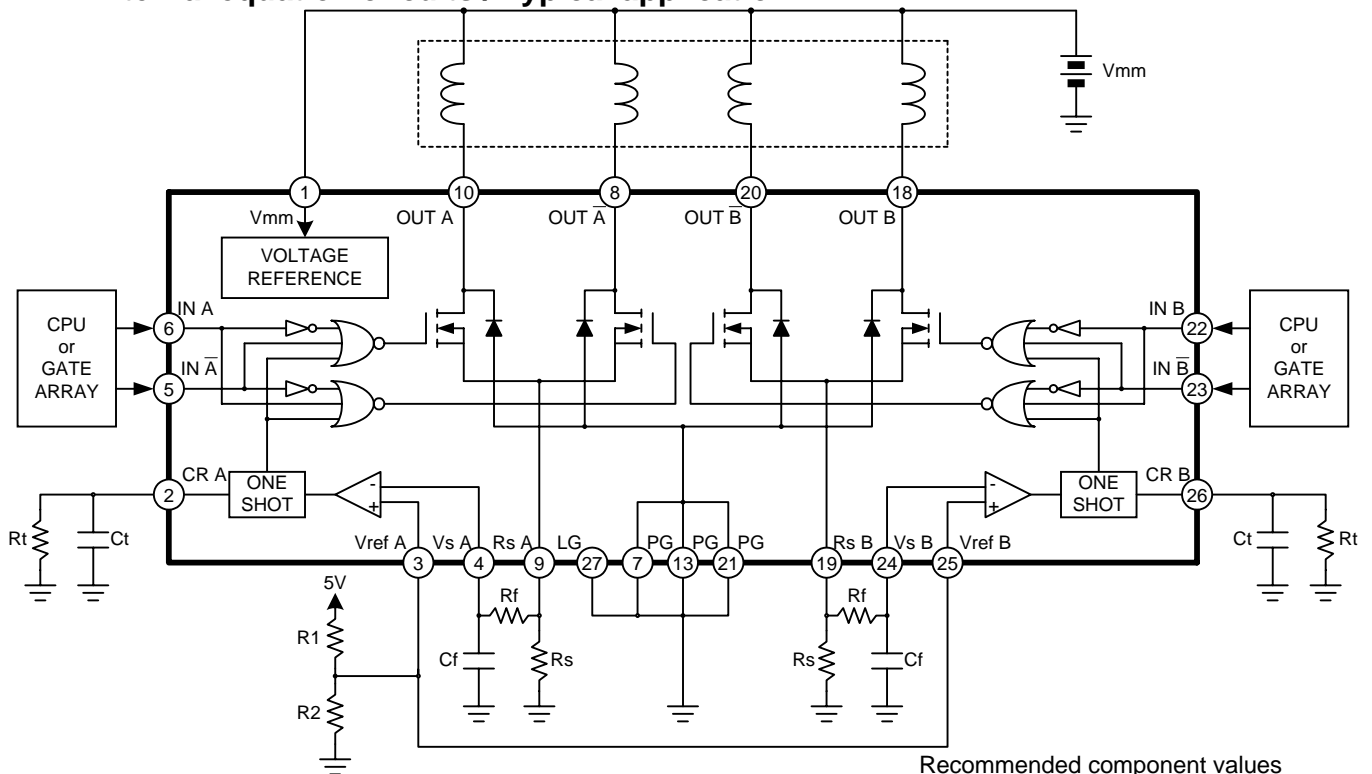

Recommended component values

Symbol	Value	Unit
R <sub>s</sub>	0.68	Ω
R <sub>t</sub>	8.2	kΩ
C <sub>t</sub>	3300	pF
R <sub>f</sub>	1	kΩ
C <sub>f</sub>	3300	pF
R <sub>1</sub> +R <sub>2</sub>	≤ 10	kΩ

Constant chopping current level

$$I_o = \frac{V_{ref}}{R_s}$$

One Shot OFF time

$$T_{off} = 0.69C_t R_t$$

### Outline dimensions

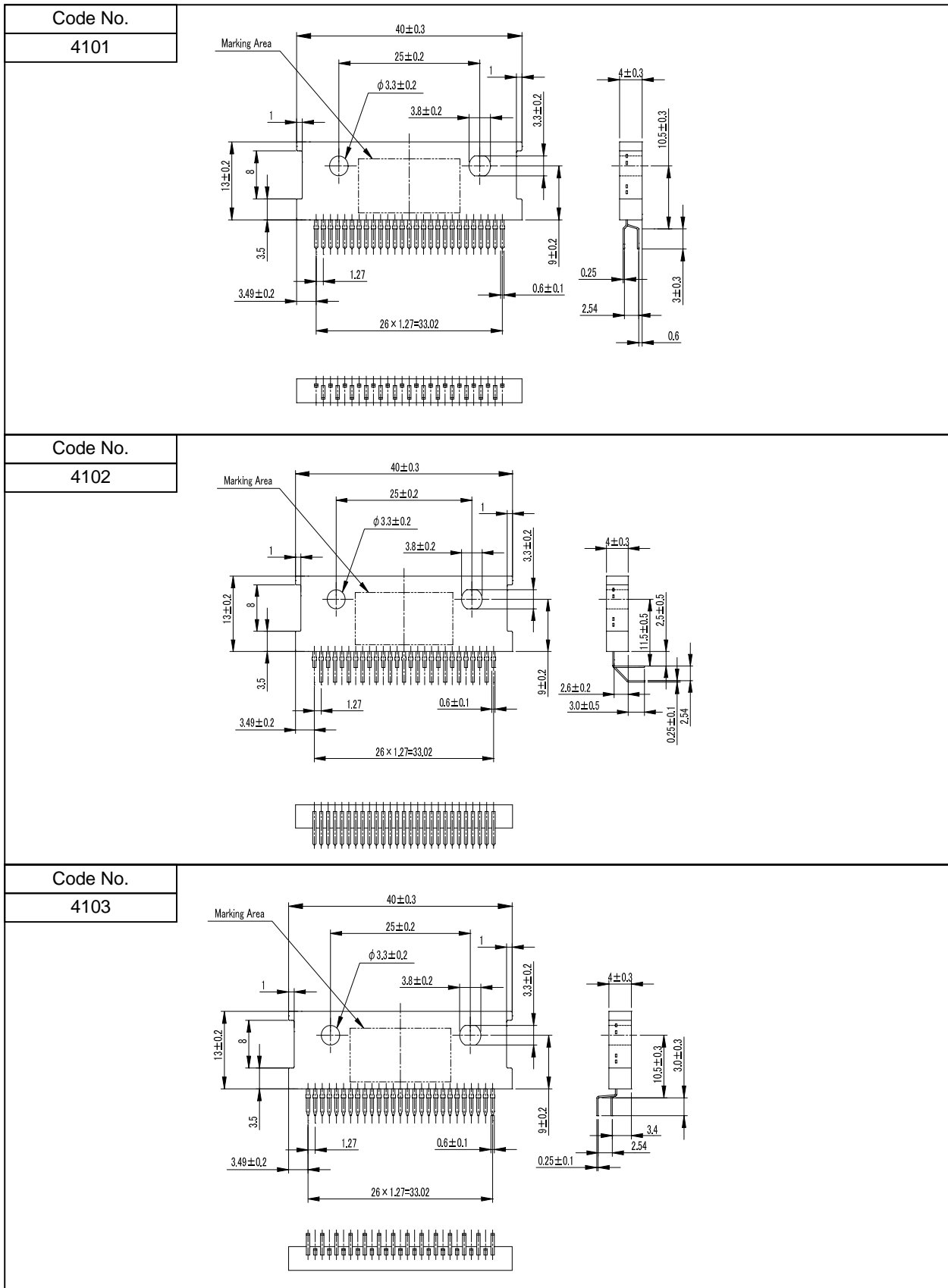

(Unit : mm)

■ This device fully meets the reliability and quality control standards described in our company's catalog. If this device is to be used in a situation where its misuse or failure might cause serious injury or death, consult with our company. Reliability and quality control standards for this device are considered adequate when it is used with the following type of end equipment.

Standard applications

Computers, OA and other office equipment, Communication terminal, Measurement machine tools, Audio-visual, Game and other amusements, Household electric appliances, Personal items, Industrial robot, etc.

Special applications where the device may or not be suitable include the following.

Transportation and conveyance (cargo loading) equipment, Primary communications equipment, Traffic signal control equipment, Fire and burglary alarms, Various safety devices, Medical equipment, etc.

Other special applications where the device reliability is not considered high enough include the following.

Atomic power control systems, Aviation equipment, Aerospace equipment, Submarine relay equipment, Life support equipment, etc.

■ Our company makes a constant effort to improve the quality and reliability of our products. However, it is the customer's responsibility to provide safety. Take the appropriate steps to prevent personal injury, fire, and damage by providing redundancy equipment, fire containment equipment, and devices to protect personnel and equipment from operational mistakes.

If you want to any more detail information and design application, please contact sales office regarding any questions you may have.

SHINDENGEN ELECTRIC MFG. CO., LTD. reserves the right to make, from time to time, such departures from the detail specifications as may be required to permit improvements in the design of its products.

The information included herein is believed to be accurate and reliable. However, SHINDENGEN ELECTRIC MFG. CO., LTD. assumes no responsibility for its use; nor for any infringements of patents or other rights of third parties, which may result from its use.